

# ~5 Watt 30M WSPR PA FOR ULTIMATE 3S

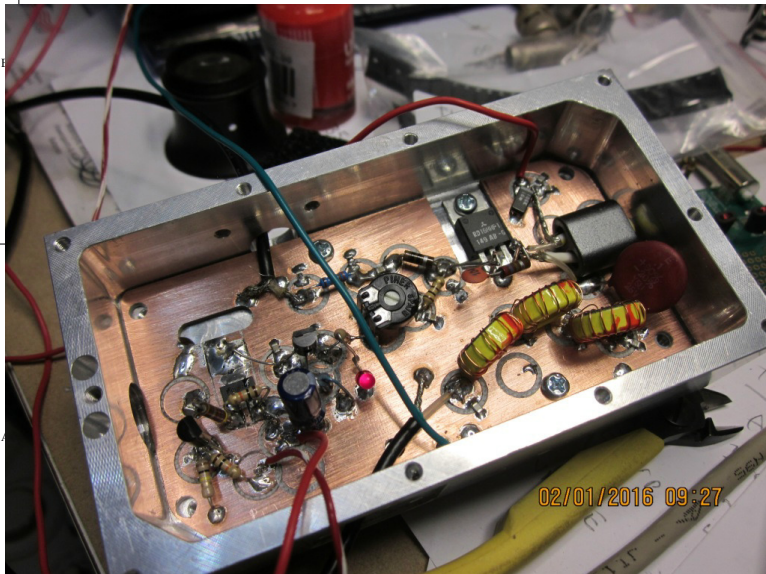

prototype board on WSPR

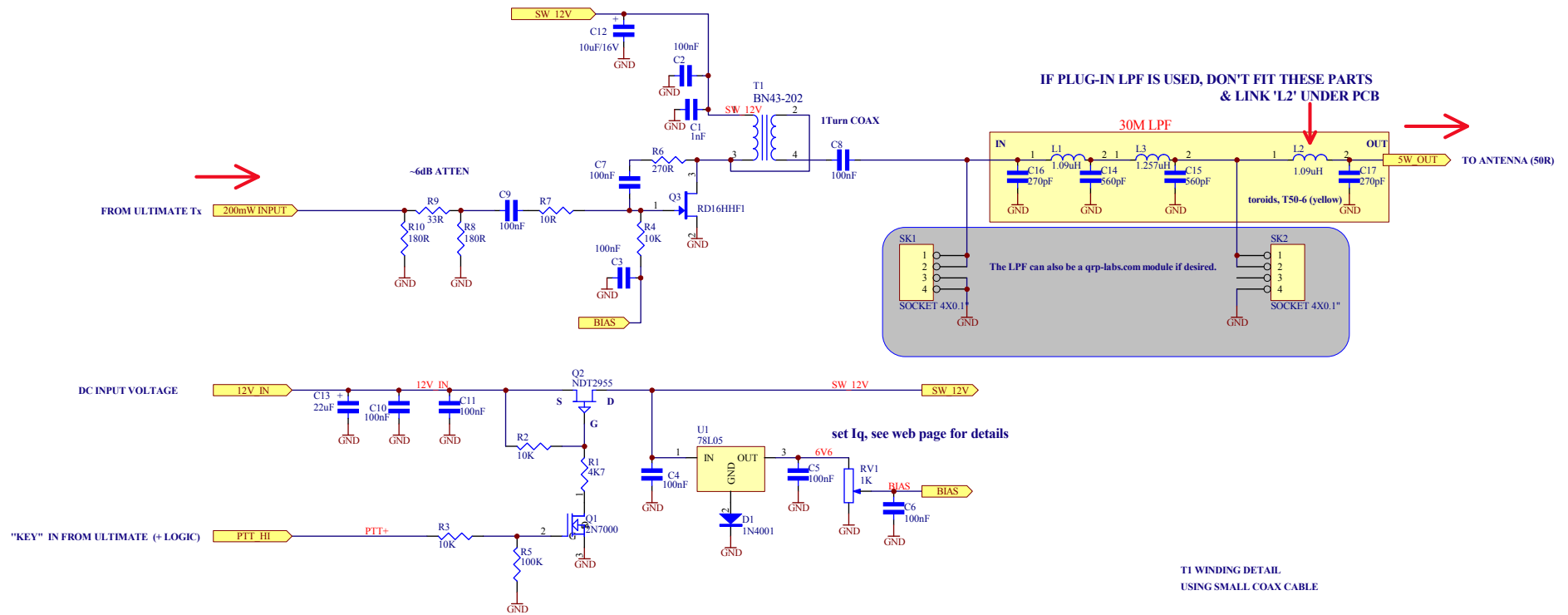
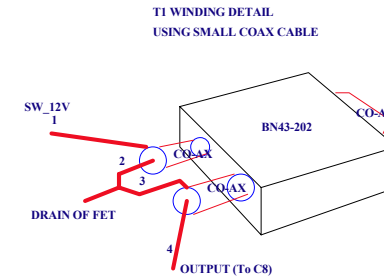

**BETTER THAN THE ABOVE,  
IS TO WIND 2 TURNS BIFILAR ONTO THE BALUN CORE.  
RESULTS IN SLIGHTLY MORE POWER OUTPUT.  
(LIGHTLY TWIST THE 2 WIRES BEFORE WINDING)**

REFER TO WWW.CARNUT.INFO FOR FURTHER DETAILS.

240216 correction to FET p/n (RD16HHF1)  
080216 minor corrections  
030216 V1.1

04-01-2016 VK3PE ULTIMATE 3S 5W PA

Title		DRAWN BY:	
Size: A3		VK3PE	
Date: 24-Feb-2016	Sheet 1	(C) 2007-2016	
Time: 09:20:52	of 1		