

RF Board or Tracking Gen V2 for simpleSA ??

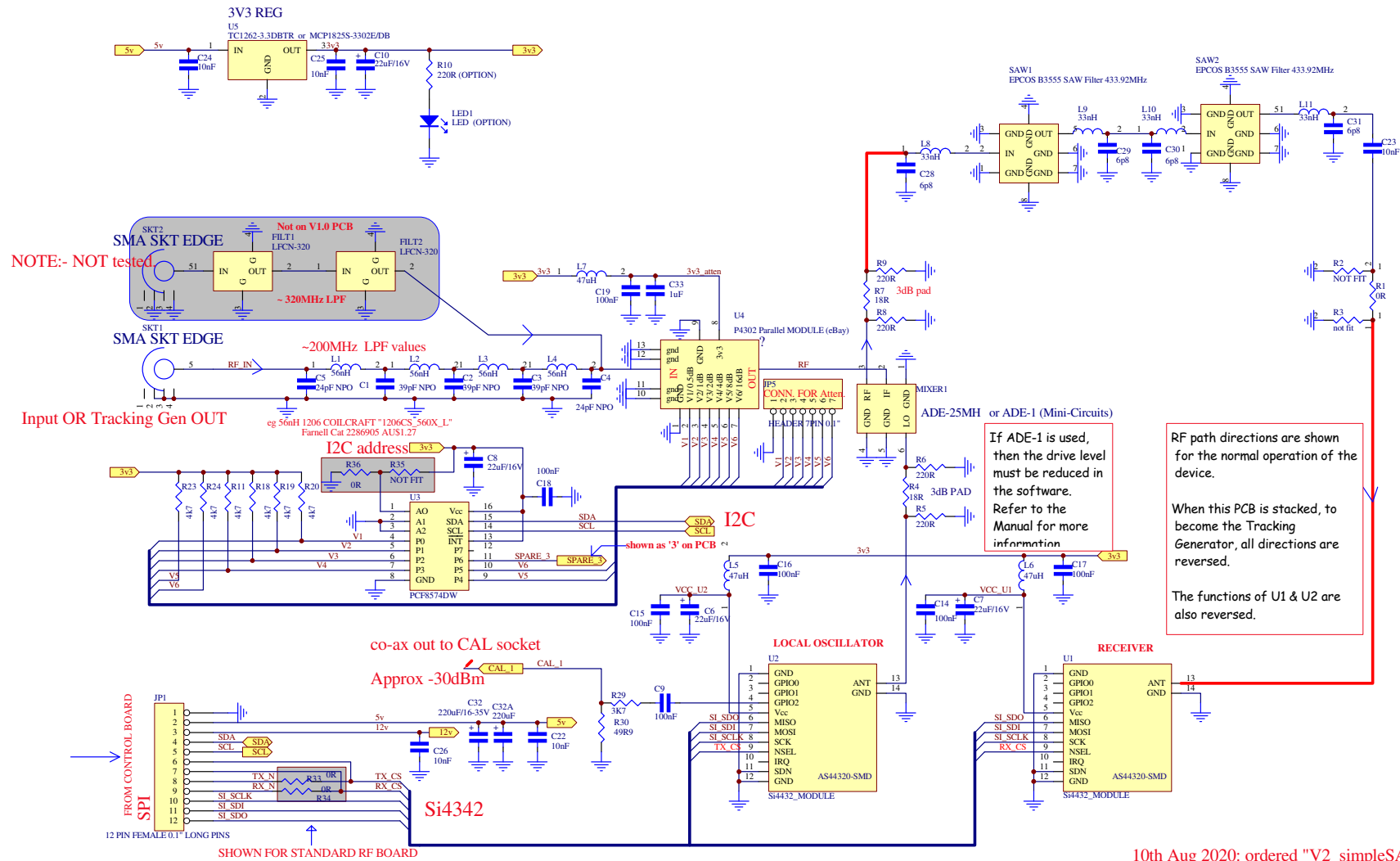

10th Aug 2020: ordered "V2_simpleSA.ZIP"
26th July tracking Gen draft MODS

V3_TRACKa4.PCB
ordered as "V2_simpleSA.ZIP"

| | | |
|----------|-------------------------------------|-----------------|
| Title | DRAWN BY: VK3PE | |
| Size: A3 | Date: 11-Aug-2020 Time: 10:45:32 | Sheet of 2 2 |
| | | (C) 2007-2019 |